

Standard Guardrail



Freestanding system

Heightsafe Systems has its very own unique design which makes the system aesthetically pleasing like no other on the market.

Our system provides a permanent edge protection without the need to mechanically fix through the roofing membrane or roof structure, and provides full protection where regular access for maintenance and inspections are required.

The strength, stability and safety is derived from our designed cantilever principal, hence there is no need to drill and puncture the roof membrane. This avoids noise disturbance during installation and potential penetrative water damaged.

Heightsafe Guardrail is Robust

With all of the systems fixings grade A2 stainless steel, its extra smooth galvanized finish (EN ISO 1461) and eco friendly re-cycled weights gives it a minimum lifespan of at least 25yrs, therefore making the system maintenance free.

Heightsafe Guardrail is Modular

The system consists of galvanized pre-assembled uprights, 2.5mt rails and our slide on weight. The 2.5mt hand and knee rails are connected with the Eazy clamp upright, which is fast, straightforward and easily adjustable to provide that perfect level finish. With no requirement for drilling, the system is easily mounted on the platform supplied.

Heightsafe Guardrail is Versatile

The system has been specifically designed to fit all shapes and sizes of flat roofs, even circular designs. The system can also cope with level changes, roof falls and difficult designs, such as ductwork passing over the roof edge and cable trays/plant mounted at the roof edge.

Membrane Protection

Our Guardrail is supplied with fluted rubber matting bonded to the underside of the foot to protect the roof membrane. The rubber weights are already membrane friendly; it is advisable for ultimate protection to add an additional piece of roof membrane under the foot and weight. This is not supplied as standard.

Testing & Certification

All our systems have been tested and approved by Satra Technology. Full documentation is available on request.

All systems comply with the following requirements:

- EN 13374
- EN ISO 14122-3, section 8.2
- European Directive 2001/45/CE
- BS6399 ; Part 2 1997
- Working at heights regs 2005

Aesthetics

The extra smooth galvanized finished can be further enhanced with application of powder coating. This can be specially ordered to the client's choice of any RAL No they require. Our collapsible system is one of many freestanding systems available in our product range.

- Radius
- 3 Rail Radius
- standard
- Top Fixed

In a choice of materials

- Galvanized
- Aluminium
- Stainless steel

We also offer bespoke systems designed by our in-house fully experienced design engineers.

Specification

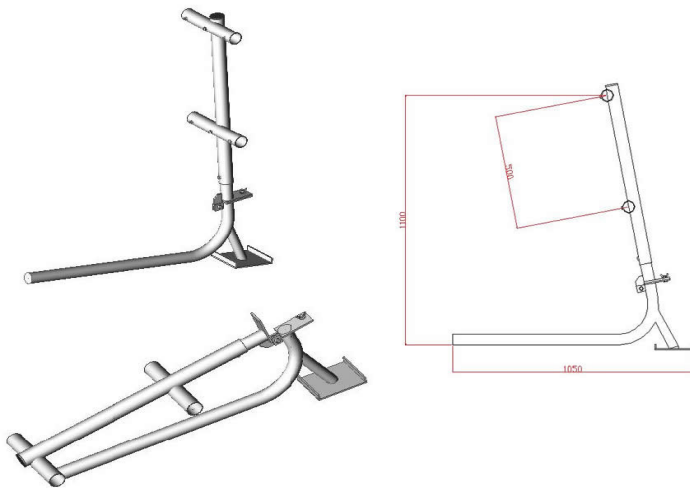

Long easy clamp upright - GR001

The upright is used as the main support to the system, the 2.5mtr rail easily slides in and is locked on using a 5mm allen key. The stop inside the upright gives 2.5mt centres naturally without the need of measuring on site.

Material – galvanized to BS EN ISO 1461 Component weight – 7 kilos

Short easy clamp upright – GR002

The upright is used as the 2nd main support to the system, the 2.5mtr rail easily slides in and is locked on using a 5mm allen key. The stop inside the upright gives 2.5mt centres naturally without the need of measuring on site.

Material – galvanized to BS EN ISO 1461 Component weight – 5.5 kilos

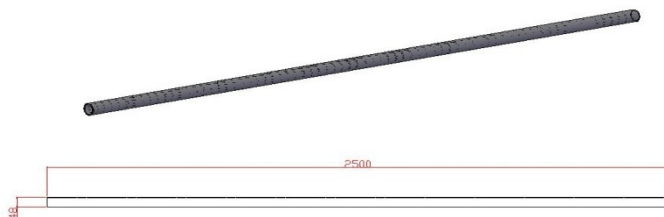

2.5mt connecting rail – GR012

The 2.5mt rail connects the long and short upright together, using 2no at a time.

Material – galvanized to BS EN ISO 1461

Component weight – 6.0 kilos

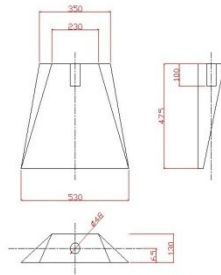
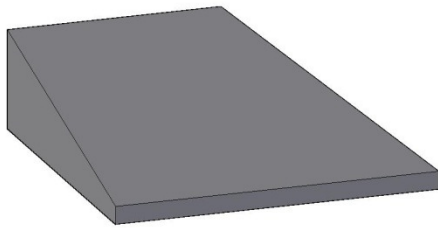

Rubber weight – GR011

The easy slide on weight gives the stability to the system.

Material – re-cycled rubber

Component weight – 20.0 kilos

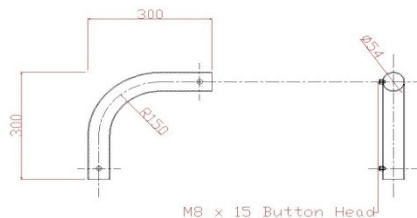

Sweeping bend – GR013

The sweeping bend provides the means to deal corners.

Material – galvanized to BS EN ISO 1461

Component weight – 1.4 kilos

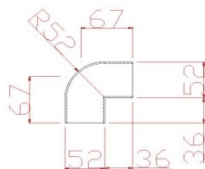

90 Degree elbow – GR014

The elbow is supplied with freestanding ends and is also used to deal short tight corners and changes in level.

Material – galvanized to BS EN ISO 1461

Component weight – 1.1 kilos

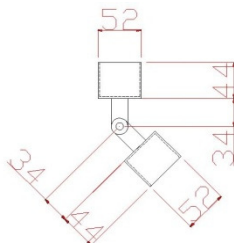
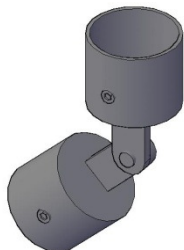

Multi bend – GR016

This allows you to deal with corners that aren't 90 degrees, and also can be used for changes in level.

Material – galvanized to BS EN ISO 1461

Component weight – 1.5 kilos

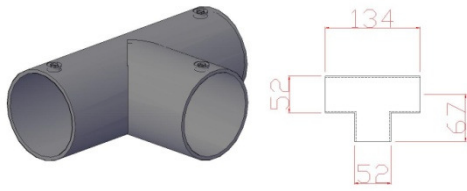

T – piece GR017

The T piece is used in conjunction with a free standing end and is used many different instances.

Material – galvanized to BS EN ISO 1461 Component weight – 1.0 kilos

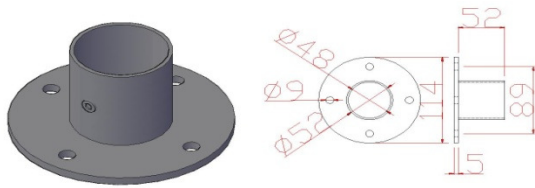

Wall bracket – GR015

Used at the end of a run where you can fix into a wall/cladding.

Material – galvanized to BS EN ISO 1461 Component weight – 1.1 kilos

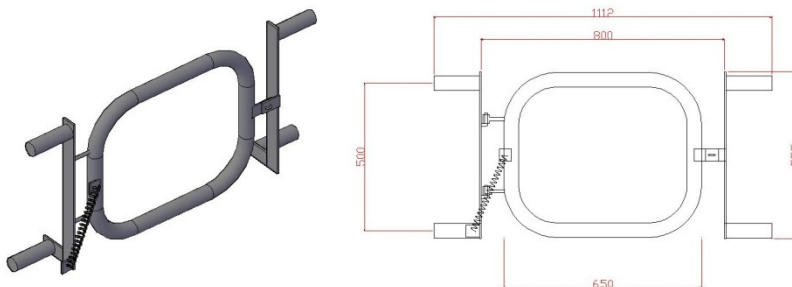

Self Closing Gate – GR020

Used to safely gain access through the our guardrail system.

Material – galvanized to BS EN ISO 1461 Component weight – 10 kilos

General

Heightsafe Systems standard guardrail is a fully designed and tested guardrail which uses cantilever balanced uprights, without the requirement for physical fixing into the roof's membrane / structure. It's a permanent freestanding guardrail which has adjustment in the uprights which caters for rise and falls of the roof, therefore keeping the system level to the parapet at all times.

Material

- Standard is manufactured from steel to BS EN10025 S275, with a galvanized finish which is extra smooth - BS EN ISO 1461.
- hand & knee rails are 48mm external diameter.
- All fixings are grade A2 stainless steel.
- All additional cast clamps used are galvanized malleable cast iron produced to BS EN 1562.
- The upright feet all have a 3mm fluted rubber pad glued on to the underside to protect the roof membrane.
- All rubber weights are roof membrane friendly.
- Any on site tube cuts can be protected by a selection of plastic cap ends, to prevent exposure to rust.

Layout

- Height of Guardrail is set at 1100mm.
- All uprights are set at 2.5mt centres, alternating the long upright and short upright. Rubber weights to be fixed on every long upright at 5mt centres.
- All free standing ends are double weighted or supported by being fixed with a wall bracket.

Test criteria

Standard was tested to the Health and Safety Executives Specialist Inspectors Report No 15.

- All testing was carried out on a roof pitch of 10 degrees as the Building Regs stipulate a flat roof can be 0 – 10 degrees in pitch.
- All guardrail testing was carried on a 5mtr straight run without any returns or double weights.
- A 0.7kn load was applied to the top rail at the very end of the 5mt straight run without moving more than 100mm at the base.
- A 0.3kn load was applied to the top rail between vertical supports in the first bay from one end. Tube deflection did not exceed 35mm.